



IOT BASED SUBSTATION MONITORING

Vrushali Date¹, Madhuri Panghvane², Sapana There³, &

Prof. MR .N.B Shaikh⁵

¹Department of Electrical Engineering of sir.vishweraya instituted of Technology Chincholi

-----***-----

Abstract - As the complexity of distribution network has grown, automation of substation has become a need of every utility company to increase its efficiency and to improve the quality of power being delivered. The proposed project which is IOT based controlling of the substation will help the utility companies, by ensuring that their local-substation faults are immediately realized and reported to their concerned departments via IOT, to provide that term of intensity intrusion is decreased. The measured parameters will send as SMS messages. The microcontroller will cooperate with the sensors introduced at the nearby substation and perform a task as commanded. Electrical parameters like current, voltage will be compared continuously to its rated value will help protect the distribution and power transformer from burning due to overload, short circuit fault, overvoltage's, and surges. Under such conditions, the whole unit is closed down through the control area including transfers detecting it, and instantly killing the electrical switch. SMS cautions can likewise be produced to demonstrate this. The utilization of GSM makes the substation astute in the sense that it can transmit signals and information and receive commands. This enables to reduce labor cost at the substation and spares time. In this manner, the observing and working effectiveness of the sub-station will definitely increment.

Key Words: Substation, SMS Messages, IOT, Relay, Monitoring.

INTRODUCTION

The distance between the generators and load may be regarding hundreds of miles hence the amount of enormous power exchange over long distances has turned out as a result of the lack of quality of the electric power. During the earlier development stages, the issues on quality of power were not frequently reported. Demanding the quality of power being delivered to the user side has raised the alarm due to the increase in demand for electricity in the customer side. A massive amount of energy is lost during the transportation of the general power which prompts the decrease in the nature of intensity got at the substation. To Improve the quality of power with a different solution, it is necessary to be familiar with what sort of constraint has occurred. Additionally, if there is any inadequacy in the protection, monitoring, and control of a power system. The system might become unstable. Therefore it necessary a monitoring system that can automatically detect, monitor, and classify the existing constraints on electrical lines. Today power still experiences control blackouts and power outages because of the absence of mechanized examination and poor deceivability of the utility over the grid. WSN will give the service provide the needed view by collecting information from the different sub-systems of the grid. A sensor node will decide information or to slightly delay this notification whether to notify the sink about this information immediately. PB COOP operation. 1) The evaluation of sense data: we define three priority levels {0, 1, and 2}) The determination of a correspondence strategy: need 0-no further activity is performed, need 2-esteem is sent to the sink since it is considered as earnest and a warning should be straightforwardly sent, need 1-we consider that esteem ought to be accounted for in light of the fact that it might motion as blame or an issue that is less pressing than need 2 information.

LITERATURE REVIEW:

The massive amount of electrical power is consumed by lighting the streets. However, vehicles pass with the meager rate in specific periods of time and parts of the roads are not involved by vehicles after some time. In this work, we propose a framework that detects the vehicle from a certain radius and automatically switches on the light until the vehicle crosses a particular radius. Logically, this system may save a significant amount of the electrical power and increases the lifetime of lamps. Also as the energy used for lightning is taken from solar energy at daytime. Thus energy used is renewable.

A GSM-based system is also integrated into the design which is used to send a message to substation if any fault in street lights is detected.

The primary operation of this system is to save the excess use of electrical energy by using solar panels and motion sensors along with less workforce requirement since the GSM modem can detect the error and location and inform it to the station.

This system automatically controls and screens the light of the roads. It can light only the parts that have and help with the maintenance of the lighting equipment

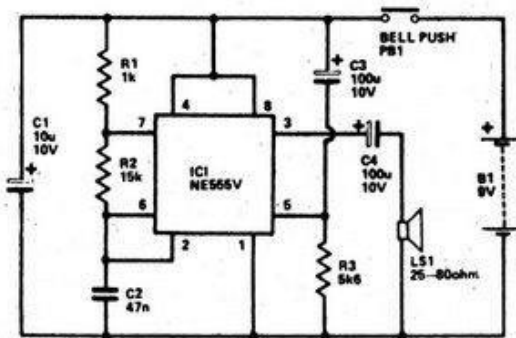

Smart Street Lighting Ssystem

Proposed Method:

The purpose behind this undertaking is to secure the unknown electrical parameters like Voltage, Current and Frequency and send these ongoing qualities over IOT based checking and control with the temperature at the power station. This venture is additionally intended to ensure the electrical hardware by working an

Electromagnetic Relay. This Relay gets enacted at whatever point the electrical parameters surpass the predefined esteems. The Relay can be utilized to run a Circuit Breaker to turn off the fundamental electrical supply. The client can send orders as IOT to peruse the remote electrical parameters. This system additionally can consequently send the continuous electrical parameters intermittently (in view of time settings) as SMS. This system can be intended to send SMS alarms at whatever point the Circuit Breaker trips or at whatever point the Voltage or Current, recurrence surpasses as far as possible.

Block Diagram:

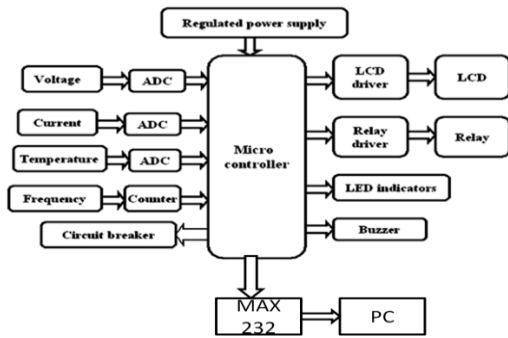

Block Diagram Description

This above block describes them in an unexpected rise in voltage, current or temperature in the appropriation transformer. Accordingly, we are proposing the computerization of the dispersion transformer from the EB substation. In the robotization, we think about the voltage, current, and temperature as the parameters to be observed as the transformer demonstrates its pinnacle affectability for the same. Subsequently, we outline a computerization framework in light of the microcontroller which constantly controls the transform the microcontroller which continuously controls the transformer. Because of the microcontroller operation, the transformer present in the substation.

Voltage Sensor:

3.1 Voltage sensor

In voltage sensors, the estimation depends on the voltage divider. Mainly two writes are of voltage sensors are accessible Capacitive compose voltage sensor and Resistive compose voltage sensor.

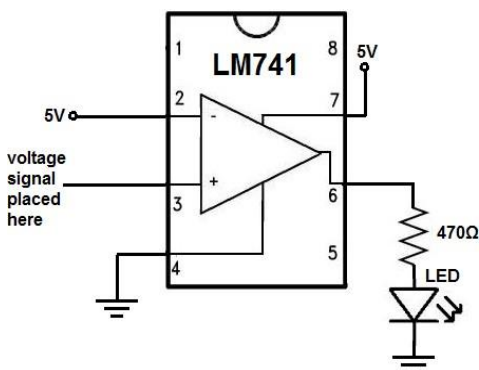

Voltage Sensor

Relay

A relay is an electrically operated .switches Many relays use an electromagnet to manage a switch mechanically, yet other working standards are likewise utilized, for example, strong state transfers. Transfers are used where it is important to access a circuit by a different low-control flag, or where one signal must control several circuits. The principal transfers were utilized as a part of long separation broadcast circuits as enhancers: they rehashed the flag rolling in from one circuit and re-transmitted it on another circuit. Transfers were utilized widely in phone trades and early PCs to perform intelligent tasks. A kind of transfer that can deal with the high power required to control an electric motor or other loads directly is called a contractor. Solid- state relays control power circuits with no moving parts, instead of using a semiconductor device to perform switching. Relays with calibrated operating characteristics and sometimes multiple operating coils are used to protect electrical circuits from overload or faults; in modern electric power systems these functions are performed by digital instruments still called "protective relays." Magnetic latching relays require one pulse of coil power to

move their contacts in one direction, and another, redirected pulse to push them back. Repeated pulses from the same input do not affect. Magnetic latching relays are used in applications where intruded on power ought not have the capacity to change the contacts. Attractive locking transfers can have either single or double curls. On a solitary loop gadget, the transfer will work one way when control is connected with one extremity and will reset when the extremity is switched.

On a double coil gadget, when a polarized voltage is applied to the reset coil, the contacts will transition. AC controlled magnetic latch relays have single coils that employ steering diodes to differentiate between operate and reset commands

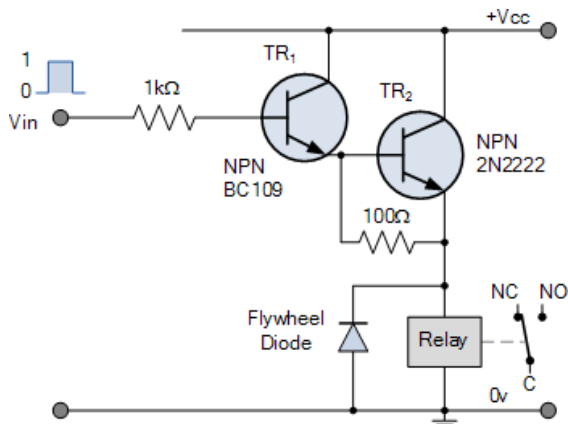

Relay Circuite

PIC Microcontroller

Peripheral Interface Controller (PIC) is microcontroller created by Microchip; PIC microcontroller is quick and simple to execute program when we look at different microcontrollers like 8051. The simplicity of programming and simple to interfacing with different peripherals PIC wound up fruitful microcontroller.

We know that the microcontroller is an integrated chip which consists of RAM, ROM, CPU, TIMERS, and COUNTERS, etc. PIC is a microcontroller which also includes of RAM, ROM, CPU, timers, counter, ADC (analog to digital converters), DAC (digital to analog converter). PIC also supports the protocols like CAN, SPI, UART for interfacing with other peripherals. PIC mainly used modified Harvard architecture and also supports RISC (Reduced Instruction Set Computer) by the above specification RISC and Harvard we can understand easily that PIC is faster than the 8051 based controller which is made-up of Von-Neuman architecture.

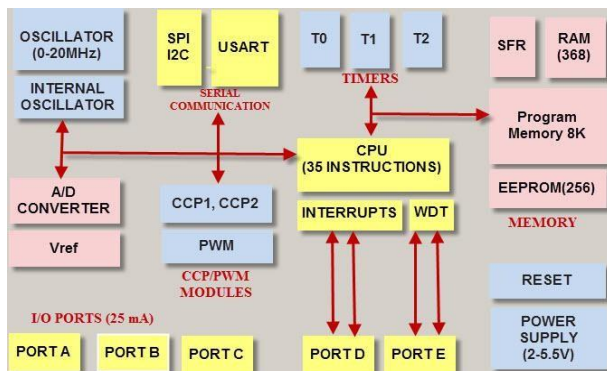

The PIC Microcontroller PIC16f877a Is One Of The Most Renowned Microcontrollers In The Industry. This Controller Is Very easy To Use, The Coding or Programming of This Controller Is Also

Erase As Many Times As Possible Because It Uses Flash Memory Technology. It has 40 Pins, And There Are 33 Pins for Input and Output. Pic16f877a Is Used In Many PIC Microcontroller Project. Pic16f877a Also Have Many Applications In Digital Electronics Circuits. Where Microcontrollers Have Never Been Used Before As In Coprocessor Applications And Timer Functions

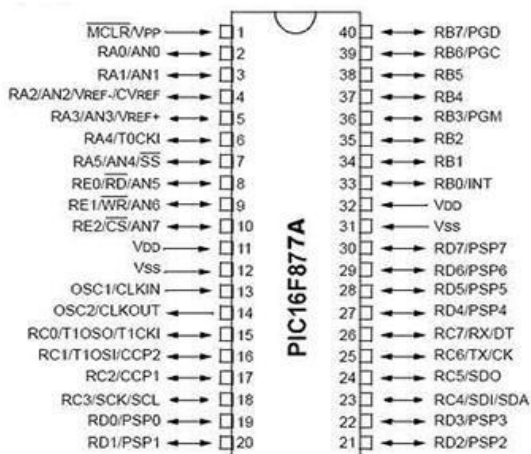

PIC Microcontroller Pin Configuration

LCD

The Flat screen LCD and plasma screens work in a completely different way. In a plasma screen, each pixel is atiny fluorescent lamp switched on or off electronically. In an LCD television.

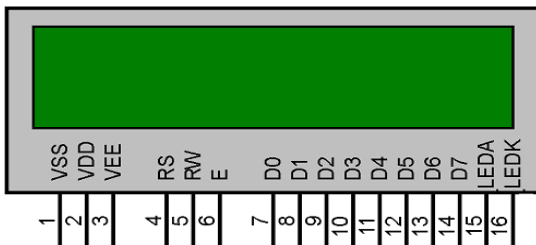

LCD DISPLAY

The pixels are turned on or off electronically utilizing fluid precious stones to pivot enraptured light. Short for fluid precious stone show, a sort of show utilized as a part of computerized watches and numerous compact PCs. LCDs use two segments of polarizing material with a fluid precious stone arrangement between them. An

electric current went through the moist causes the crystals to align so that light cannot pass through them. A liquid-crystal display (LCD) is a flat-panel display or other electronically modulated optical devices that use the light-modulating properties of liquid crystals.

Current sensor:

A current sensor is a gadget that distinguishes electric current in a wire and creates a flag relative to that present. The produced flag could be a simple voltage or present or even an advanced yield. The created flag can be then used to show the deliberate current in an ammeter, or can be put away for advance investigation in an information securing system, or can be utilized for control.

CURRENT SENSOR

Frequency sensor:

This basic RF signal indicator circuit can be utilized to follow the nearness of RF signals and electromagnetic commotion in your local location, office or shop. It can be a helpful instrument while

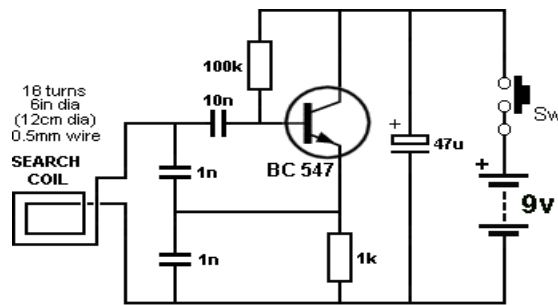

testing or outlining RF circuits. It can likewise be utilized to recognize electrical commotion in your premises.

Analog to digital converter:

More often than not, transducers are additionally used to change over the information simple factors as streams or voltages. The computerized numbers utilized here are paired, i.e '0' and '1'. The '0' demonstrates the 'off' state, and '1' speaks to the 'on' state. Thus all the simple qualities are changed over into advanced twofold qualities by an ADC. For instance, on the off chance that we need to introduce a caution in our home or at some office, whose capacity is to set off if there should be an occurrence of fire or overheating. Our entire caution system will be electronic. However, the temperature sensor will give simple qualities at the yield subsequent to detecting the temperature. In this manner to change over the differing amounts of heat in digital or discrete qualities, we need to utilize a simple to advanced converter.

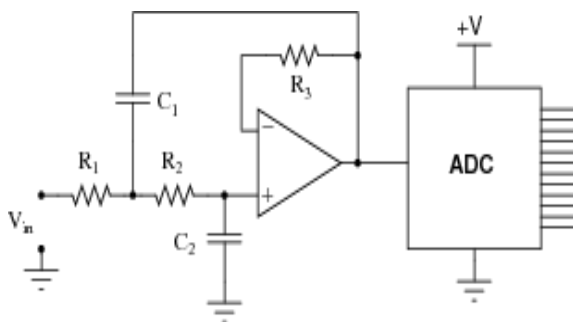

Analog to digital convertar

Circuit Diagram Explanation The + 5v power supply is provided for the microcontroller to perform its operation. four different types of the load will be connected to sub-station to analyze the voltage, current, frequency, temperature monitoring. if pre- set value exceed the relay will trip the circintimation through IOT.

RESULT DISCUSSION:



Parameters	Specification	Input	Output
Voltage sensor	Step down	(0-230)V AC	(0-5)VDC
Current sensor	Step down	(0-10)Amp	(0-2)Amp
PIC controller	Monitor & control	(0-5) V	(0-5) V
Relay	Trip	(0-12)v	(0-5)V
IOT	Control and monitoring	Monitoring	Control

Advantages

- The immediate attention can take place if a variation happens in the sub-station parameters.
- IOT based control is easy to identify the fault in any variant.
- The various parameters can be modified and analyzed continuously through a network.

Application

- Sub-station
- Power generation
- Distribution area.

Conclusion:

On completion of our project "Substation Monitoring and Control using Microcontroller and IOT," we can improve the quality of power transferred and provide uninterrupted power supply. Also, real time monitoring of different parameters is done which can ensure safety to the substation and its equipment. Besides, utilizing very propelled IC's with the assistance of developing innovation, the undertaking has been effectively executed. In this manner, the undertaking has been effectively composed and tried. The designed system provides easy control of remote substation. It enables two-way interchanges. The substation can speak with the service organization to show, with what sort of fault, a substation has been related. The exact location of the substation can also be determined by sending location coordinates of the substation. Finally, the experimental output verified.

REFERECE:

1. Amit Sachan, "Microcontroller based substation monitoring and control system with GSM modem" ISSN: 2278-1676 Volume 1, Issue 6 (July-Aug. 2012), PP 13-21

Natalie Matta, Rana Rahim-Amoud, Leila Merghem- Boulahia, AkilJrad, "A wireless sensor network for substation monitoring and control in the smart grid" (IEEE)

1. M. Kezunovic, Y. Guan, M.Ghavami, "New concept and solution for monitoring and control system for the 21 st century substation" (IEEE)



2. B.A. Carreras, V. E. Lynch, D. E. Newman and I. Dobson, "Blackout Mitigation Assessment in Power Transmission Systems," Hawaii International Conference on System Science, January 2003.
3. Xiaomeng Li and Ganesh K. Venayaga moorthy, "A Neural Network-Based Wide Area Monitor for a Power System," IEEE Power Engineering Society General Meeting, Vol. 2, pp: 1455-1460, 2005.
4. Argonne National Laboratory, "Assessment of the Potential Costs and Energy Impacts of Spill Prevention, Control, and Countermeasure requirements for Electric Utility Substations," Draft Energy Impact Issue Paper, 2006.









