



IOT Based Implementation of Disaster Monitoring at Public Places and Industrial Area Through Smart Poles

Thakare Sachin, Patil Darshan, Lole Aishwarya, Shirsath Rutuja &

Prof. Nitin S Patil

*Department of Electrical Engineering Sandip Foundation's Sandip Institute of Technology and Research
Centre Nashik*

-----***-----

Abstract - Main aim of this system is to provide energy efficient system which provides continuous monitoring of environmental parameters like air quality, earthquake and floods. So that people & higher government authorities will get to know about the accidents quickly. To make the system energy efficient, lights from the pole will be turn on & off depending on external light environment.

This project will be implemented on existing roadside streetlamps & helpful for generating immediate alert in extreme situations to avoid casualties. 24*7 monitoring of environmental parameters form anywhere. It will be helpful for speed up the rescue operations in flood & earthquake. To avoid the use of external energy, system included with rotating solar panel. All these features make the old streetlight poles SMART. In this proposed system, Air quality sensor is used to monitor hazardous gases & smoke detection. This will trigger an alarm when the air quality goes down beyond a certain level, means when there are sufficient amount of harmful gases are present in the air like CO₂, smoke, alcohol, benzene and NH₃. A water level sensor for flood detection & vibration sensor for earthquake detection are used. System will display readings from sensors on webpage through internet. So that government officials will be alert at that exact movement. An alarm will be on, when danger situations are detected, so that people will get start to reach safer places. Street lights on pole will be turn on & off automatically, depending on external light environment. This system is be powered through sun tracking solar panel & will be the efficient and lifetime source of energy for the system.

Key words: **Internet of things, Disaster management, ThingSpeak, IFTTT**

INTRODUCTION:

Gas leak accidents & air contamination is a major issue these days. These accidents are causing many life casualties. It is necessary to generate immediate alerts for situations like this. So that people can go at safer places on time. It is essential to screen Air Quality and monitor it for future and sound living for all. So, we propose an air quality & temperature observing system that help us to check and monitor live air quality temperature through IOT.

This project will be implemented on existing roadside streetlamps & helpful for generating immediate alert in extreme situations to avoid casualties. 24*7 monitoring of environmental parameters form



anywhere. It will be helpful for speed up the rescue operations in flood & earthquake. To avoid the use of external energy, system included with rotating solar panel. All these features make the old streetlight poles SMART. In this proposed system, Air quality sensor is used to monitor hazardous gases & smoke detection. This will trigger an alarm when the air quality goes down beyond a certain level, means when there are sufficient amount of harmful gases are present in the air like CO₂, smoke, alcohol, benzene and NH₃. System will display readings from sensors on webpage through internet. So that government officials will be alert at that exact movement. An alarm will be on, when danger situations are detected, so that people will get start to reach safer places. Street lights on pole will be turn on & off automatically, depending on external light environment. This system is be powered through sun tracking solar panel & will be the efficient and lifetime source of energy for the system.

Need of Project

Gas leak accidents & air contamination is a major issue these days. These accidents are causing many life casualties. It is necessary to generate immediate alerts for situations like this. So that people can go at safer places on time. It is essential to screen Air Quality and monitor it for future and sound living for all. So, we propose an air quality & temperature observing system that help us to check and monitor live air quality temperature through IOT.

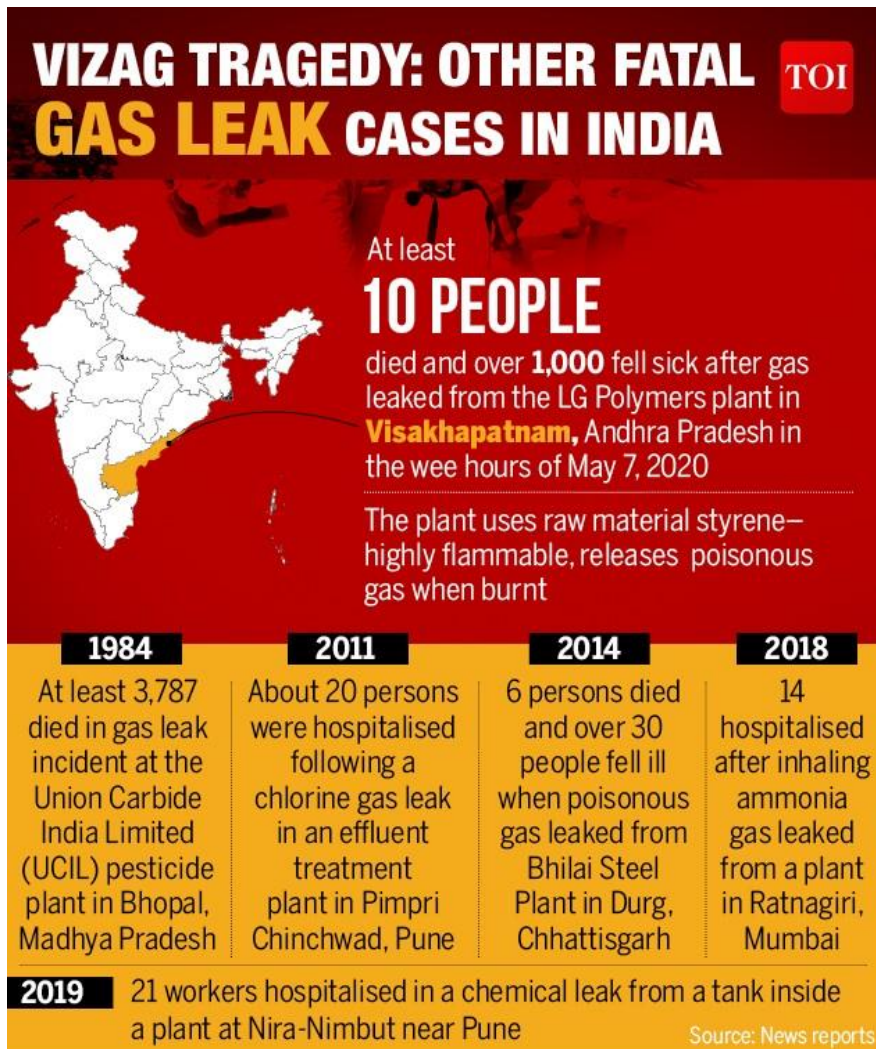

Objectives of Project

Main aim of this project is to design self-powered system which provides continuous monitoring of environmental parameters like air quality & temperature. So that people & higher government authorities will get to know about the accidents quickly. To make the system energy efficient, lights from the pole will be turn on & off depending on external lightenvironment. Some of design objectives of system are as bellow:

- Immediate alert will be generated in accidental situations to avoid casualties.
- 24*7 monitoring of air quality & temperature form anywhere.
- Will be helpful for speed up the rescue operations in situation like gas leak.

- Generated database will be useful to improve public health & studies.
- Since the system is solar powered, no need to provide external energy.

Motivation:

Not a single living thing can survive without air. Air is the most important element for living. According to the SDG (Sustainable Development Goals) by the UN (United Nations) there are seventeen goals to transform the world to clean, healthy and natural way to live in because at this time there are several problems in human life. The SDG says, Goal 3: Ensure healthy lives and promote well-being for all at all ages, Goal 7: Ensure access to affordable, reliable, sustainable and modern energy for all, Goal 12: Ensure sustainable consumption and production patterns, Goal 13: Take urgent action to combat climate change and its impacts, Goal 14: Conserve and sustainably use the oceans, seas and marine resources, Goal 15: Sustainably manage forests, combat desertification, halt and reverse land degradation, halt biodiversity loss. These are the main reason why the topic was chosen for the research purpose.

Problem Statement

In this project we have to design and implement air quality and temperature monitoring system with alert

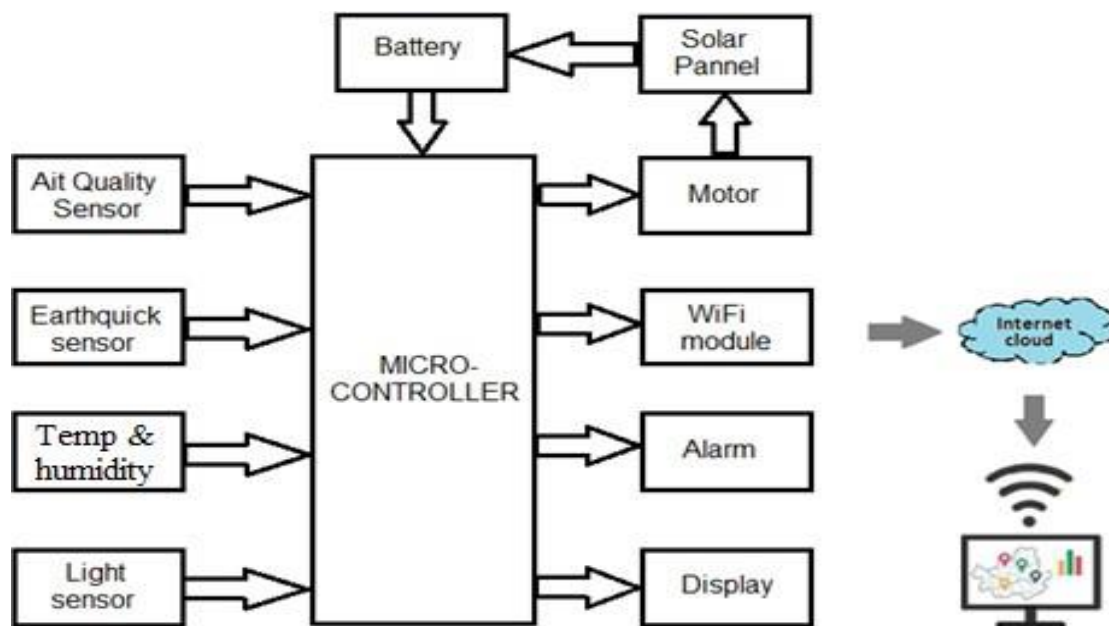

through IOT. System will be powered trough solar energy to make it independent on external energy.

PROPOSED BLOCK DIGRAM

Selection of Development Tools: Selecting a perfect development tool is most important. To develop every microcontroller based system, a set of software and hardware tools are required. Software tools for editing and debugging and troubleshooting the microcontroller program. While hardware tools for burning computer code into microcontroller and testing microcontroller hardware. A good development tools must have following properties:

- Simple to use
- Not many steps execution
- Inexpensive
- Must include basic functions like editor, debugger, compiler
- Also, power supply and basic hardware required and I/O pins connector facility
- Cross-platform development
- Must support different programming language and computer operating system

Selection of Microcontroller

A microcontroller is a heart of every automation system. It is a small, low cost and self-contained on chip computer that can be used as an embedded system. Microcontrollers usually must have low-power requirements since many devices they control are battery-operated. . A microcontroller usually includes:

- An 8 or 16 bit microprocessor.
- A little measure of RAM.
- Programmable ROM and flash memory.
- Parallel and serial I/O.
- Timers and signal generators.
- Analog to Digital and Digital to Analog conversion

Considerations While Choosing Microcontroller:

Following parameters are mainly consider for microcontroller selection:

- Number of input output pins
- Amount of memory required

- Need of inbuilt ADC and DAC
- Processing speed and capacity
- Power requirement for operation
- Programming language
- Size should be less
- Software and hardware tools required

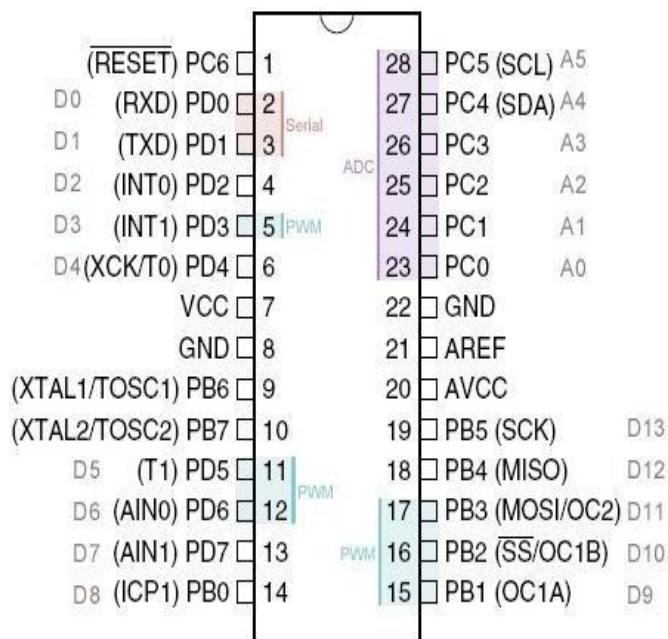

MQ135 Gas Sensor:

MQ135 Gas Sensor module for Air Quality having Digital as well as Analog output. Sensitive material of MQ135 gas sensor is SnO₂, which with lower conductivity in clean air. When the target combustible gas exist, The sensors conductivity is more higher along with the gas concentration rising. MQ135 gas sensor has high sensitivity to Ammonia, Sulphide and Benze steam, also sensitive to smoke and other harmful gases. It is with low cost and suitable for different application. It can be used for family, Surrounding environment noxiousgas detection device, Apply to ammonia, aromatics, sulfur, benzene vapor, and other harmfulgases/smoke, gas detection, tested concentration range: 10 to 1000 ppm.

Specifications:

- Responds to gases: CO₂, smoke, alcohol, benzene and NH₃

- Power Supply: +5V
- Current Consumption: 100-300mA



MQ135

4.1.2 DHT11 sensor:

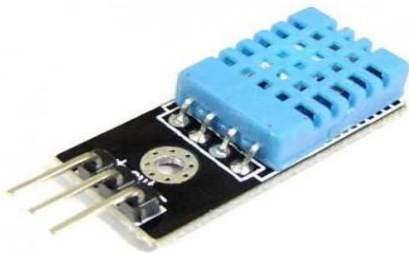

DHT11 is a Humidity and Temperature Sensor, which generates calibrated digital output. DHT11 can be interface with any microcontroller and get instantaneous results. DHT11 is a low cost humidity and temperature sensor which provides high reliability and

long term stability. It uses a capacitive humidity sensor and a thermistor to measure the surrounding air, and outputs a digital signal on the data pin (no analog input pins needed). It's very simple to use. This module makes is easy to connect the DHT11 sensor to a microcontroller as includes the pull up resistor required to use the sensor. Only three connections are required to be made to use the sensor - Vcc, Gnd and Output. Features:

- Power Supply: 3.3~5.5V DC
- Output: 4 pin single row
- Measurement Range: Humidity 20-90%RH, Temperature 0~50°C
- Accuracy : Humidity +-5%RH, Temperature +-2°C

- Resolution: Humidity 1%RH, Temperature 1°C
- Interchangeability: Fully Interchangeable
- Long-Term Stability : $<\pm 1\%$ RH/year

LDR Sensor

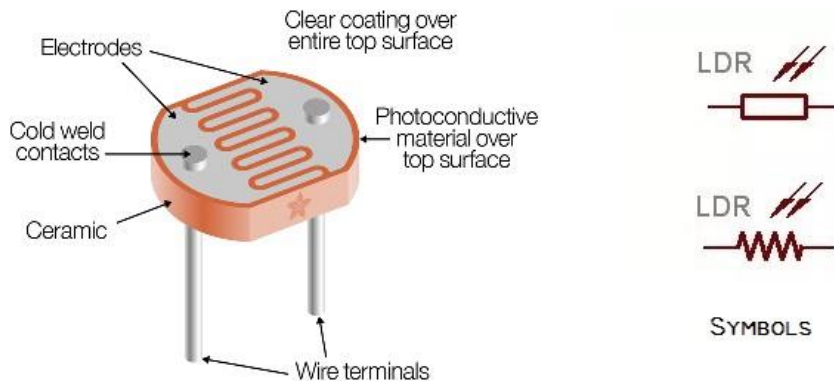

WEB PAGE RESULT:

Last entry: [less than a minute ago](#)
Entries: 18

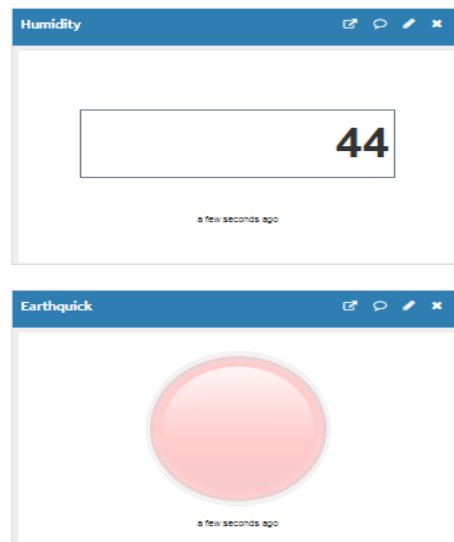
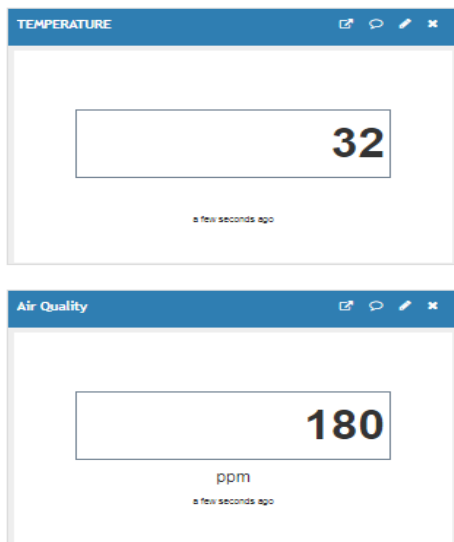

6.1 Conclusion

By implementing this system on street poles, issue of external energy requirement & maintenances of street lights can be reduce. Due to use of IOT alert, lot of lives can be save before the disasters like gas leak. Use of solar energy makes the system energy independent & reliable. By using such a Smart Pole we can easily monitor on changing environmental conditions. This project helps to provide alarm system of upcoming environmental dangerous conditions. This system provides the database for the research studies on natural disaster

References

- [1] Xiaoke Yang, Lingyu Yang, Jing Zhang, “A WiFi-enabled indoor air quality monitoring and control system”, Control & Automation (ICCA), 13th IEEE International Conference-2017.
- [2] Sujuan Liu, Chuyu Xia, Zhenzhen Zhao, “A low-power real-time air quality monitoring system using LPWAN based on LoRa”, Solid-State and Integrated Circuit Technology (ICSICT), 13th IEEE International Conference, 2016.
- [3] M.F.M Firdhous, B.H Sudantha, P.M Karunaratne “IoT enabled proactive indoor air quality monitoring system for sustainable health management”, 2nd International Conference on Computing and Communications Technologies (ICCCT), 2017.
- [4] R du Plessis, A Kumar, GP Hancke, “A wireless system for indoor air quality monitoring”, Industrial Electronics Society , IECON 2016 - 42nd Annual Conference of the IEEE, 2016.
- [5] Yonggao Yang, Lin Li, “Polluino: An efficient cloud-based management of IoT devices for air quality monitoring” IEEE 2nd International Forum Research and Technologies for Society and Industry Leveraging a better tomorrow (RTSI), 2016.
- [6] Sneha Jangid, Sandeep Sharma, “An embedded system model for air quality monitoring” 3rd International Conference Computing for Sustainable Global Development (INDIACom), 2016.
- [7] H. Ali, J. K. Soe, Steven. R. Wel, “A real-time ambient air quality monitoring wireless sensor network for schools in smart cities”, IEEE First International Conference on Smart Cities Conference (ISC2), 2015.



Websites:

1. <http://www.ijrucc.org>
2. <https://ieeexplore.ieee.org/>
3. <http://www.learningaboutelectronics.com>
4. <https://www.arduino.cc>
5. <https://github.com>
6. http://timesofindia.indiatimes.com/articleshow/75590112.cms?utm_source=contentofinterest&utm_medium=text&utm_campaign=cppst

