

INTEGRATION OF DUAL – AXIS SOLAR TRACKING AND CLEANING SYSTEM

Anitha S¹, Nagraja Holalu², Karthik Kumar K³, Kishore Kumar A⁴, Puneeth S⁵

¹Professor, Dept. of electronics and Communication Engineering, RajaRajeswari College of Engineering, Bengaluru ^{2,3,4,5} Student, Dept. of electronics and Communication Engineering, RajaRajeswari College of Engineering, Bengaluru

Abstract - India, one of the biggest energy consumers in the world, is increasingly seeking solar energy as a form of viable green energy. However, environmental factors such as dust accumulation have a great impact on the efficiency of a photovoltaic panel, which could lower energy output by 50%. On the other hand, most solar panels stand stationary and do not follow the sun's movement, reducing the amount of energy they can absorb. The goal of this project is to present a Smart Solar Care System that will improve panel performance by combining a dual-axis sun-tracking mechanism with an automatic cleaning unit. Controllers utilized for dynamic alignment of the solar panel with the sun's position are based on light sensors and microcontrollers. With regular cleaning, dust is cleared off by water spraying or dry brushing.

Keywords: dual axis solar tracking with cleaner, automated solar cleaning, and solar tracking system

Introduction

Solar energy has become a significant driving force in the movement away from fossil fuels and toward renewable resources on an international scale. Among all solar technologies, photovoltaic or PV systems are the most popular because they can be deployed at any scale, require minimal maintenance, and are clean. Their effectiveness, however, is dependent upon a variety of factors, including the angle of the sun, the condition of the panels themselves, and the surrounding environment. Static solar panels underperform because they cannot optimally track the sun throughout the day. Automatic cleaning systems, in turn, prevent soiling, particularly in dry or dusty conditions, ensuring uniformity in energy production. Efficiency and reliability in solar panels need to be enhanced due to the increasing demand for electricity and the urge towards sustainability taking place globally. The project involves the dual-axis solar tracking system, which has an automated cleaning mechanism for optimization in the capture of energy and reduction in maintenance cost

LITERATURE SURVEY

A. solar tracking system: a technique of solar power output enhancement Renewable energy sources are those that remain available without reduction over time, and are the

driver for much research into this field. Solar energy is a renewable resource, which is free and clean. The only limiting factor to harnessing this energy is in the environmental aspects. Solar tracking permits overcoming these disadvantages. This paper presents a review of several solar tracking systems to improve the outputs of solar power. The results of the solar tracking systems were higher in efficiency than fixed solar systems. Also, since dual-axis tracking systems monitor exposure to the Sun on both axes, they perform better compared to single-axis ones.

However, it is not advisable for small PV arrays to employ solar trackers since the energy consumption of their driving systems amounts for 2% to 3% of the energy gain they offer. Normally, photovoltaic panels are installed on either rooftops or open spaces in order to capture sunlight. Most of the time, they are fixed at a latitude-corresponding angle. Though quite rare, some individuals might manually adjust the direction of the panel in order to follow the sun. In order for a solar panel to create the most energy, it has to be perpendicular to the light source.

B. Since the sun travels around during the day and throughout the year, a solar panel should follow the path of the sun for maximum power output. This can be achieved by a tracking mechanism that keeps the panel aligned to the light source continuously. Solar Panel Automated Cleaning Tracking and Cooling System (ACTCS) Switching to renewable energy sources is essential given India's growing power needs and the country's transition to sustainable energy. One of the simplest renewable energy sources to implement widely is solar energy. It can be deployed on both public and private building rooftops in addition to solar farms. It can be deployed on both public and private building rooftops in addition to solar farms.

In solar panels, working efficiency ranges from 15% to 22%. This efficiency can be drastically reduced by various elements: shadows, snow, high temperatures, dust, filth, bird droppings, pollen, and sea salt. A cleaning system can resolve the issue of dust and filth. Because of incident angles, in conventional installations the solar panels reach 100% efficiency for only two to three hours daily. The ideal operating temperature for solar panels is below 50°C, which is maintained with the aid of a cooling system.

The operating efficiency of the panels can be increased by 45% to 85% by integrating all three systems.

C) Current Solar PV Panel Cleaning System Procedures and Upcoming Machine Learning Implementation Opportunities
Solar photovoltaic systems are an emerging green energy source that are gaining popularity in off-grid and national systems worldwide. The performance is influenced by soiling, meteorological regime, and sun insolation regional variations. PV cell temperature rise and soiling affect the performance and lifespan of power plants to a great extent, thereby influencing the LCoE. The paper discusses the factors involved in the performance of PV modules and reviews their application in the models that involve cleaning intervention decision-making. It describes the current cleaning practices and their evaluation, as well as a critical analysis of the need for effective cleaning for performing soiling management operations at PV power plants. Along with ocular inspections, the authors propose the use of scientific equipment for the optimum intervention of cleaning. They have proposed a diagrammatic representation of a decision-making model integrating machine learning technologies with data processing techniques and numerous factors. Data science and machine learning applied to solar PV panel cleaning systems will take renewable energy far ahead.

D) Dual-Axis Solar Tracking Mechanism Simulation and Optimization
The aim of this study is to simulate and optimize a tracking mechanism for the purpose of improving PV system efficiency. The tracker proposed in this work has two equatorial/polar degrees of freedom, sometimes referred to as dual-axis or bi-axial. Each of the two movements is powered by one linear actuator. The mechatronic concept is set up by integrating commercial software packages ADAMS and EASY5 into a virtual prototyping environment. Three items are subject to the optimization process: the bi-axial tracking programme, the control system, and the mechanical device. Each of these changes improves the energy efficiency of the tracking system in its own way. In the evaluation, data about summer solstice-when a day is the longest in the year-are considered; net energy gain of 5866% is observed against a comparative fixed system. Additional numerical simulations during several representative days show that the annual net energy gain is approximately 42%, thus justifying the use of this tracking system.

II. METHODOLOGY

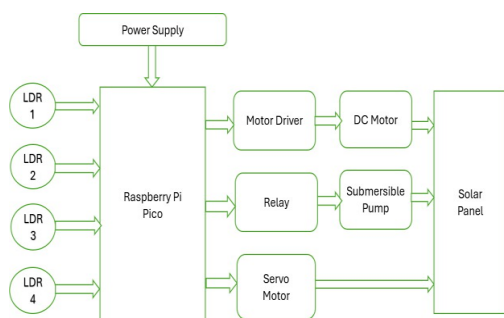

Fig1. Block Diagram of Integration of Dual-axis Solar Tracking and Cleaning System.

The first parts of the system are Light Dependent Resistors, LDRs. They are mounted in such a way that they measure sunlight from all different angles. These LDRs are attached to the Raspberry Pi Pico microprocessor. The Arduino calculates the angle of maximum sunlight by analysing voltage changes from the LDRs. Then it forwards control signals to two servo motors-one responsible for azimuth, which is horizontal movement, and the other for elevation, or vertical movement. Throughout the day, these motors will move the solar panel to follow the path of the sun. Another connection is the relay circuitry connected to the Arduino Uno, which acts as an electronic switch and thus could handle higher power with safety. This relay manages the motors for tracking and cleaning parts. A submersible pump is wired to a water storage unit in the area of the diagram showing the cleaning mechanism, while the relay employs a power circuit to actuate it. This pump supplies water to clean the surface of the solar panels. The mechanical wiper, driven by a servo motor, also wipes off dust and other particles from the panel. In this way the solar panel will be able to track the sun with good precision from dawn to dusk. The cleaning mechanism is turned on periodically, usually in the morning, to keep the surface clean.

III. PROBLEM STATEMENT

Solar energy is one of the promising clean power source alternatives, but efficiency in solar panels declines with time due to dust and dirt accumulation, as well as poor sunlight capture. If solar panels are not monitored on a timely basis and cleaned properly, there can be up to a 30% loss in the potential capacity of the panels. The consequence is that returns diminish, operation and maintenance costs increase, and the life span of the system reduces. To get peak performance and long-term reliability of solar energy systems, we need appropriate solar care strategies, such as solar tracking and cleaning.

IV. OBJECTIVE

The general aim of the work is to design an effective solar energy system that is self-regulatory. Specific objectives include:

Creating a dual-axis tracking system that accurately follows the sun's path. The control system's development using microcontrollers to automate the movement of panels.

- Developing an automated cleaning process that would not damage panels yet keep them transparent.
- Analyse the energy produced by the smart system versus a static panel under identical conditions. Upon successful completion of these objectives, high-

performance low-maintenance next-generation solar power systems can be realized.

- Designing a dual-axis solar tracking and cleaning system to ensure maximum energy output can be produced by changing the orientations of the solar panels in view to accurately track the sun during the day.
- Dual-axis tracking allows for adjustments both on the horizontal and vertical axes to improve capture when seasons change or when conditions vary.
- Automating the regular cleaning of panels.
- Integration of tracking with a cleaning mechanism that requires minimal resources.
- It reduces maintenance costs and results in optimal performance. The system contributes to increased output of solar energy and sustainability through both the tracking and cleaning foci.

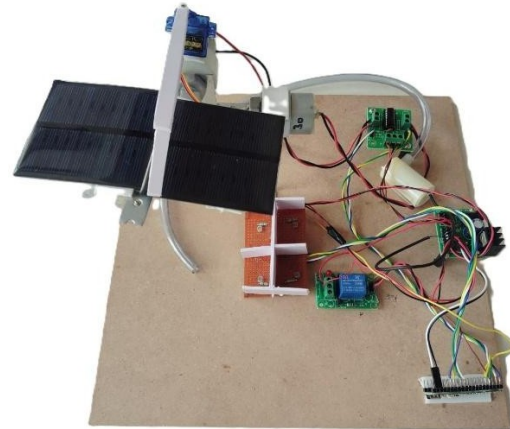

Fig 2. Working Model

V. SYSTEM IMPLEMENTATION

1. HARDWARE COMPONENTS

Main components used for the project are:

1. Raspberry pi pico: A microcontroller for monitoring and automating systems

Two DC motors are needed, one for each axis: elevation and azimuth. The motors provide dual-axis tracking.

2. Light Dependent Resistors (LDRs) measure the strength of sunlight.
3. Servo motors or DC motors for the cleaning mechanism.
4. Relay: The use of one or more relays controls high-power circuits with low-power signals.
5. The board obtains external energy from the battery, while the solar panel converts sunlight into electrical energy.

B. WORKING MECHANISM

The dual-axis solar tracking system adjusts both in the horizontal azimuth and vertical elevation directions to position the panel at the ideal angle throughout the day.

The Raspberry pi pico thus regulates the servo motors using the light intensity detected by LDR sensors from different angles. Consequently, the exact tracking of the sun from dawn to dusk becomes possible for the solar panel. The cleaning mechanism is programmed to turn on at specific intervals-usually once in the morning-to keep the surface free from dust and debris. In this case, cleaning can be achieved by using either a dry brush mechanism or a relay-controlled water spray system.

VI. RESULTS AND DISCUSSION

RESULTS Table demonstrates that while each system creates a remarkable improvement separately, together, the effects become synergistic-resulting in a dramatic rise in total solar energy production. For instance, a location like Mysuru, Karnataka, well-known for dust accumulation and high solar irradiance, will be able to employ both technologies to ensure maximum efficiency and return on investment from a solar installation. The dual-axis tracking mechanism assures maximum capture of sunlight from dawn to dusk, allowing rotation of the solar panel about the azimuth and elevation axes. Other benefits recorded:

1. Manual maintenance is reduced, thus advantageous to remote installations.
2. Resilience in the system through automated responses to real-time light conditions.

Energy use by motors and sensors is at a minimum, ensuring a positive net energy gain. Given the modular nature of this design, scaling up for large industrial solar farms or even scaling down for residential units becomes possible. Experimental results indicate that this integrated setup outperforms conventional static panels in energy output and system reliability

Conclusion	
Scenario	Expected Output Boost
With dual-axis tracking	+35–45%
With regular cleaning	+10–30%
With both	+60% or more

Table 1: Both tracking and cleaning

VII. CONCLUSION AND FUTURE SCOPE

A. CONCLUSION

This project proposes the design and installation of a smart solar tracking and cleaning system, providing improved maintenance and efficiency for photovoltaic panels. The prototype in this paper effectively validates how automated cleaning and dual-axis sun tracking can be integrated into a compact and cost-effective system. While this was designed for a single-panel system, it incorporates a modular design quite effortlessly for larger solar arrays. Future enhancements could be made by incorporating sensors—such as dust sensors—that would trigger cleaning based on actual conditions of the panels.

B. FUTURE SCOPE

Further development for Integration of dual axis solar tracking and cleaning would include, but not be limited to:

- Hydrophobic or self-cleaning nanotechnology-based coatings may reduce or eliminate the need for mechanical cleaning in future designs.
- Energy harvesting from the environment: Motors and control units could be powered by ambient wind or panel vibrations for micro-energy harvesting, thus enhancing the general energy efficiency.
- IoT integration: Integrating Internet of Things modules into the system will provide capabilities for remote control and monitoring via web dashboards or smartphones.

REFERENCES

- [1] K. Kumba, P. Upender, P. Buduma, M. Sarkar, S. P. Simon, and V. Gundud, "Solar tracking systems: Advancements, challenges, and future directions: A review," *Energy Reports*, vol. 12, pp. 3566-3583, 2024.
- [2] D. Dahlioui, S. M. Alaoui, B. Laarabi, and A. Barhdadi, "Waterless cleaning technique for photovoltaic panels on dual-axis tracker," *Research Square*, Apr. 18, 2022, doi: 10.21203/rs.3.rs-1507277/v1.
- [3] P. Singh, R. Pahuja, M. Karwasra, S. Beniwal, M. Bansal, and A. Dadhich, "Dual Axis Solar Tracking System for Solar Panel," *Bulletin of Electrical Engineering and Informatics*, vol. 5, no. 4, pp. 403-411, Dec. 2016.
- [4] J. Y. Muhammad, M. T. Jimoh, I. B. Kyari, M. A. Gele, and I. Musa, "A Review on Solar Tracking System: A Technique of Solar Power Output Improvement," *Engineering Science*, vol. 4, no. 1, pp. 1-11, Jan. 2019.
- [5] A. Shah, P. Shelar, and B. Shirame, "Automated Cleaning Tracking and Cooling System (ACTCS) for Solar Panel," *International Journal of Engineering Research & Technology (IJERT)*, vol. 10, no. 01, Jan. 2021.
- [6] N. Khadka et al., "Current Practices of Solar Photovoltaic Panel Cleaning System and Future Prospects of Machine Learning Implementation," *IEEE Access*, vol. 8, pp. 135962-135976, 2020, doi: 10.1109/ACCESS.2020.3011553.
- [7] K. J. Alaameri, A. J. Ramadhan, and A. S. Maklakov, "Design of dual-axis solar tracking system with integrated cleaning system: Case study of Najaf city, Iraq," in *AIP Conference Proceedings*, Jan. 2022, Art. no. 020001, doi: 10.1063/5.0066840.
- [8] K. Patil et al., "Dual Axis Solar Tracker with Cleaner," *International Journal For Research in Applied Science and Engineering Technology (IJRASET)*, vol. 10, no. IV, Apr. 2022, doi: 10.22214/ijraset.2022.41498.
- [9] K. Ehlers, J. Eng, N. Gallo, M. Kelley, J. Lung, and B. Weitzenkamp, "Dual Axis Solar Tracker With Automated Cleaning System," B.S. thesis, Dept. Mech. Eng., Santa Clara Univ., Santa Clara, CA, 2022.
- [10] C. Jamroen et al., "A low-cost dual-axis solar tracking system based on digital logic design: Design and implementation," *Sustainable Energy Technologies and Assessments*, Jan. 2020, doi: 10.1016/j.seta.2019.100618.
- [11] C. Alexandru, "Simulation and Optimization of a Dual-Axis Solar Tracking Mechanism," *Mathematics*, vol. 12, no. 7, Art. no. 1034, 2024, doi: 10.3390/math12071034.
- [12] K. Patel et al., "Design and implementation of Sun Tracking Solar Panel and Smart Wiping Mechanism